

**Color test point for surface mounting**

**GHS series**

- This test point is for chip mounter use.
- There are 6 colors. Each signal line can be color-coded.
- Possible to put tester lead from side or oblique upward.
- Material Metal part: Phosphor bronze  
Resin part: Nylon9T (UL94V-0)
- Finish GHS-2.0-G: Gold plating over nickel base  
GHS-2.0-S: Tin plating over nickel base
- Resin color: BLACK, RED, YELLOW, GREEN, BLUE, WHITE

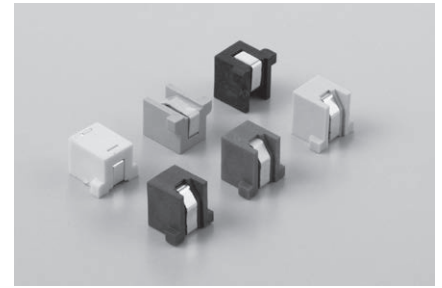

**Part No.**

Part No.	Packing state
GHS-2.0-G □	Bulk (100pcs/pack)
GHS-2.0-G-T □	Reel (400pcs/reel)
GHS-2.0-S □	Bulk (100pcs/pack)
GHS-2.0-S-T □	Reel (400pcs/reel)

□ : Color designation (BLACK, RED, YELLOW, GREEN, BLUE or WHITE)

**Example of use**

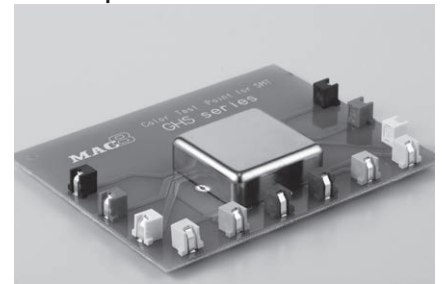

**Dimensional drawing**

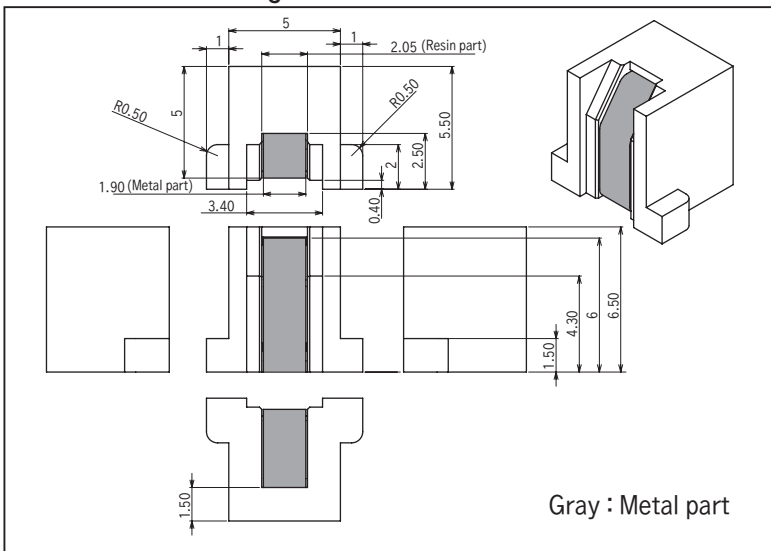

**Recommended land information**

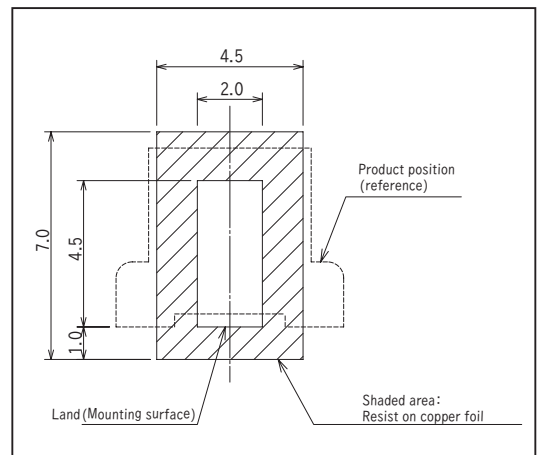

**Reel dimensions**

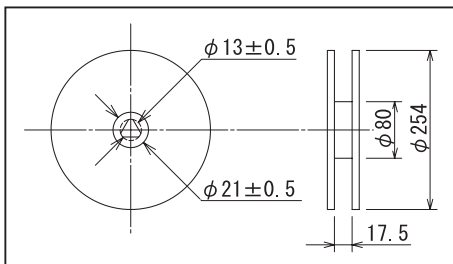

**Tape dimensions**

