

Terminal for additional PC board

BW series (100 pcs/pack)

- By using this, a slave board can be put above a main board.
- Once a spare land is made at the edge of a main board, a slave board can be placed on it soon if necessary.
- Fit this product in a master board and solder. Then, fix a slave board above by tightening with a screw.
- This is adaptive for the PC board with the thickness of t1.6, t2.0 and t3.2.
- Material: Phosphor bronze
- Finish: Tin plating over nickel base
- Rated current: 20A

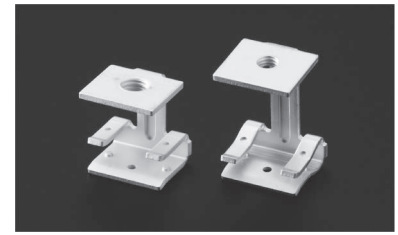

■ Example of usage

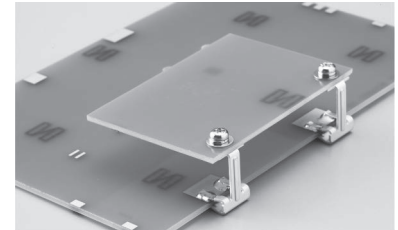

■ Part No. **M3 P=0.5** **M4 P=0.7**

Part No.	A	B	H	M	Adaptive printed board thickness	C
BW-1.6-10-M3	1.5	1.5	10	M3	1.6	8
BW-2-10-M3	1.9	1.5	9.8	M3	2.0	8
BW-3.2-10-M3	3.1	1.5	9.2	M3	3.2	8
BW-1.6-10-M4	1.5	2.1	10	M4	1.6	8
BW-2-10-M4	1.9	2.1	9.8	M4	2.0	8
BW-3.2-10-M4	3.1	2.1	9.2	M4	3.2	8
BW-1.6-15-M3	1.5	1.5	15	M3	1.6	9
BW-2-15-M3	1.9	1.5	14.8	M3	2.0	9
BW-3.2-15-M3	3.1	1.5	14.2	M3	3.2	9
BW-1.6-15-M4	1.5	2.1	15	M4	1.6	9
BW-2-15-M4	1.9	2.1	14.8	M4	2.0	9
BW-3.2-15-M4	3.1	2.1	14.2	M4	3.2	9

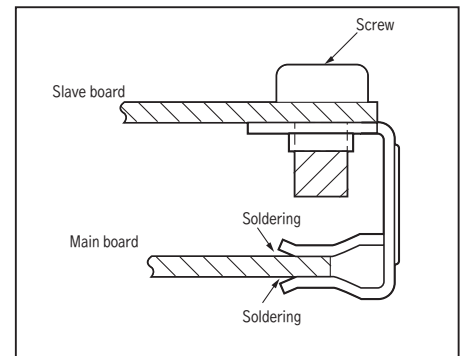

■ Recommended land information

